

Thin Film Chip Inductor AL Series

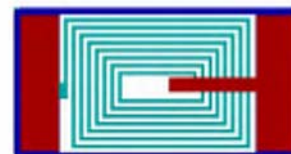
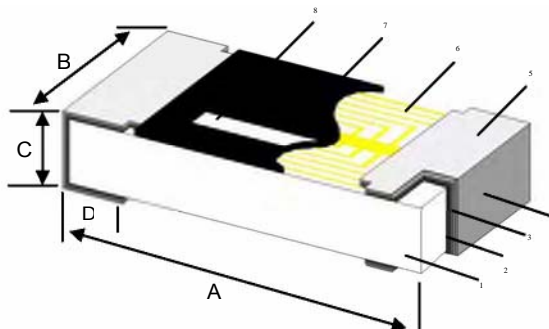
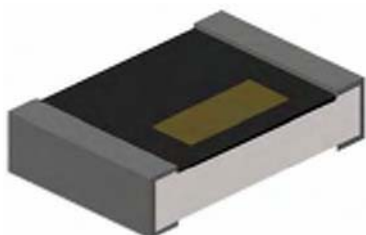

Construction

1	Alumina Substrate	4	External Electrode (Sn)	7	Overcoat
2	Inner Electrode (Ni-Cr)	5	Edge Electrode	8	Marking
3	Barrier Layer (Ni)	6	Cu Circuits		

Features

- Photolithographic single layer ceramic chip -
- High SRF, excellent Q, superior temperature stability
- Tight tolerance of $\pm 1\%$ or ± 0.1 nH
- Self resonant frequency controlled within 10%
- Stable inductance in high frequency circuit
- Highly stable design for critical needs

Dimensions

Unit: mm

Type	Size (Inch)	A	B	C	D	Weight (g) (1000pcs)
AL01	0201	0.60 \pm 0.05	0.30 \pm 0.05	0.23 \pm 0.05	0.15 \pm 0.05	0.3
AL02	0402	1.0 \pm 0.05	0.5 \pm 0.05	0.32 \pm 0.05	0.2 \pm 0.10	0.9
AL03	0603	1.6 \pm 0.10	0.8 \pm 0.10	0.45 \pm 0.10	0.3 \pm 0.20	2.97

Applications

- Cellular Telephone, Pagers and GPS Products -
- VCO, TCXO Circuit and RF Transceiver Module -
- Wireless LAN, Bluetooth Module, Communication Appliances

Part Numbering

AL	02	G	T	10N
Product Type	Dimensions	Inductance Tolerance	Packaging Code	Inductance
	1: 0201 2: 0402 3: 0603	B: ± 0.1 nH C: ± 0.2 nH S: ± 0.3 nH W: ± 0.05 nH F: $\pm 1\%$ G: $\pm 2\%$ H: $\pm 3\%$	T: Taping Reel	1N0: 1nH 10N: 10nH 20N8: 20.8nH R10: 100nH

.Viking is capable of manufacturing the optional spec based on customer's requirement.

Standard Electrical Specifications

AL01 Chip Inductors / Standard Type

Inductance (nH)	Inductance Tolerance (nH or %)	Quality Factor min.	SRF (GHz) min.	DCR (Ω) max.	IDC (mA) max.
0.1	$\pm 0.1, 0.2, 0.3nH$	8 / 500MHz	9	0.20	400
0.2	$\pm 0.1, 0.2, 0.3nH$	8 / 500MHz	9	0.20	400
0.3	$\pm 0.1, 0.2, 0.3nH$	8 / 500MHz	9	0.20	400
0.4	$\pm 0.1, 0.2, 0.3nH$	8 / 500MHz	9	0.25	350
0.5	$\pm 0.1, 0.2, 0.3nH$	8 / 500MHz	9	0.25	350
0.6	$\pm 0.1, 0.2, 0.3nH$	8 / 500MHz	9	0.25	350
0.7	$\pm 0.1, 0.2, 0.3nH$	8 / 500MHz	9	0.30	300
0.8	$\pm 0.1, 0.2, 0.3nH$	8 / 500MHz	9	0.30	300
0.9	$\pm 0.1, 0.2, 0.3nH$	8 / 500MHz	9	0.30	300
1.0	$\pm 0.1, 0.2, 0.3nH$	8 / 500MHz	9	0.30	300
1.1	$\pm 0.1, 0.2, 0.3nH$	8 / 500MHz	9	0.35	300
1.2	$\pm 0.1, 0.2, 0.3nH$	8 / 500MHz	9	0.35	300
1.3	$\pm 0.1, 0.2, 0.3nH$	8 / 500MHz	9	0.45	250
1.4	$\pm 0.1, 0.2, 0.3nH$	8 / 500MHz	9	0.45	250
1.5	$\pm 0.1, 0.2, 0.3nH$	8 / 500MHz	9	0.45	250
1.6	$\pm 0.1, 0.2, 0.3nH$	8 / 500MHz	9	0.55	200
1.7	$\pm 0.1, 0.2, 0.3nH$	8 / 500MHz	9	0.55	200
1.8	$\pm 0.1, 0.2, 0.3nH$	8 / 500MHz	9	0.55	200
1.9	$\pm 0.1, 0.2, 0.3nH$	8 / 500MHz	9	0.55	200
2.0	$\pm 0.1, 0.2, 0.3nH$	8 / 500MHz	8	0.70	200
2.1	$\pm 0.1, 0.2, 0.3nH$	8 / 500MHz	8	0.70	200
2.2	$\pm 0.1, 0.2, 0.3nH$	8 / 500MHz	8	0.70	200
2.3	$\pm 0.1, 0.2, 0.3nH$	8 / 500MHz	8	0.80	150
2.4	$\pm 0.1, 0.2, 0.3nH$	8 / 500MHz	8	0.80	150
2.5	$\pm 0.1, 0.2, 0.3nH$	8 / 500MHz	8	0.80	150
2.6	$\pm 0.1, 0.2, 0.3nH$	8 / 500MHz	8	0.80	150
2.7	$\pm 0.1, 0.2, 0.3nH$	8 / 500MHz	8	0.80	150
2.8	$\pm 0.1, 0.2, 0.3nH$	8 / 500MHz	6	1.00	150
2.9	$\pm 0.1, 0.2, 0.3nH$	8 / 500MHz	6	1.00	150
3.0	$\pm 0.1, 0.2, 0.3nH$	8 / 500MHz	6	1.00	150
3.1	$\pm 0.1, 0.2, 0.3nH$	8 / 500MHz	6	1.00	150
3.2	$\pm 0.1, 0.2, 0.3nH$	8 / 500MHz	6	1.00	150
3.3	$\pm 0.1, 0.2, 0.3nH$	8 / 500MHz	6	1.00	150
3.4	$\pm 0.1, 0.2, 0.3nH$	8 / 500MHz	6	1.20	150
3.5	$\pm 0.1, 0.2, 0.3nH$	8 / 500MHz	6	1.20	150
3.6	$\pm 0.1, 0.2, 0.3nH$	8 / 500MHz	6	1.20	150
3.7	$\pm 0.1, 0.2, 0.3nH$	8 / 500MHz	6	1.20	150
3.8	$\pm 0.1, 0.2, 0.3nH$	8 / 500MHz	6	1.20	150
3.9	$\pm 0.1, 0.2, 0.3nH$	8 / 500MHz	6	1.20	150
4.0	$\pm 0.1, 0.2, 0.3nH$	8 / 500MHz	6	1.20	150
4.4	$\pm 0.1, 0.2, 0.3nH$	8 / 500MHz	6	1.30	140
4.7	$\pm 0.1, 0.2, 0.3nH$	8 / 500MHz	6	1.40	130
4.9	$\pm 0.1, 0.2, 0.3nH$	8 / 500MHz	6	1.60	130
5.6	$\pm 2, \pm 5\%$	8 / 500MHz	4	1.80	130
6.1	$\pm 2, \pm 5\%$	8 / 500MHz	4	2.00	120
6.8	$\pm 2, \pm 5\%$	8 / 500MHz	4	2.30	110
7.4	$\pm 2, \pm 5\%$	8 / 500MHz	4	2.80	110
8.2	$\pm 2, \pm 5\%$	8 / 500MHz	3	3.00	110
9.1	$\pm 2, \pm 5\%$	8 / 500MHz	3	3.25	100
9.2	$\pm 2, \pm 5\%$	8 / 500MHz	3	3.25	100
10	$\pm 2, \pm 5\%$	8 / 500MHz	2	3.50	80

AL02 Chip Inductors / Standard Type

Inductance (nH)	Inductance Tolerance (nH or %)	Quality Factor min.	SRF (GHz) min.	DCR (Ω) max.	IDC (mA) max.
0.2	$\pm 0.1, 0.2, 0.3\text{nH}$	13 / 500MHz	14	0.10	800
0.3	$\pm 0.1, 0.2, 0.3\text{nH}$	13 / 500MHz	14	0.10	800
0.4	$\pm 0.1, 0.2, 0.3\text{nH}$	13 / 500MHz	14	0.10	800
0.5	$\pm 0.1, 0.2, 0.3\text{nH}$	13 / 500MHz	14	0.15	700
0.8	$\pm 0.1, 0.2, 0.3\text{nH}$	13 / 500MHz	14	0.15	700
0.9	$\pm 0.1, 0.2, 0.3\text{nH}$	13 / 500MHz	14	0.15	700
1.0	$\pm 0.1, 0.2, 0.3\text{nH}$	13 / 500MHz	12	0.15	700
1.1	$\pm 0.1, 0.2, 0.3\text{nH}$	13 / 500MHz	12	0.15	700
1.2	$\pm 0.1, 0.2, 0.3\text{nH}$	13 / 500MHz	12	0.15	700
1.3	$\pm 0.1, 0.2, 0.3\text{nH}$	13 / 500MHz	10	0.25	700
1.4	$\pm 0.1, 0.2, 0.3\text{nH}$	13 / 500MHz	10	0.25	700
1.5	$\pm 0.1, 0.2, 0.3\text{nH}$	13 / 500MHz	10	0.25	700
1.6	$\pm 0.1, 0.2, 0.3\text{nH}$	13 / 500MHz	10	0.25	560
1.7	$\pm 0.1, 0.2, 0.3\text{nH}$	13 / 500MHz	10	0.25	560
1.8	$\pm 0.1, 0.2, 0.3\text{nH}$	13 / 500MHz	10	0.25	560
1.9	$\pm 0.1, 0.2, 0.3\text{nH}$	13 / 500MHz	8	0.35	560
2.0	$\pm 0.1, 0.2, 0.3\text{nH}$	13 / 500MHz	8	0.35	560
2.1	$\pm 0.1, 0.2, 0.3\text{nH}$	13 / 500MHz	8	0.35	440
2.2	$\pm 0.1, 0.2, 0.3\text{nH}$	13 / 500MHz	8	0.35	440
2.3	$\pm 0.1, 0.2, 0.3\text{nH}$	13 / 500MHz	8	0.35	440
2.4	$\pm 0.1, 0.2, 0.3\text{nH}$	13 / 500MHz	8	0.35	440
2.5	$\pm 0.1, 0.2, 0.3\text{nH}$	13 / 500MHz	8	0.35	440
2.6	$\pm 0.1, 0.2, 0.3\text{nH}$	13 / 500MHz	8	0.35	440
2.7	$\pm 0.1, 0.2, 0.3\text{nH}$	13 / 500MHz	8	0.35	440
2.8	$\pm 0.1, 0.2, 0.3\text{nH}$	13 / 500MHz	6	0.45	380
2.9	$\pm 0.1, 0.2, 0.3\text{nH}$	13 / 500MHz	6	0.45	380
3.0	$\pm 0.1, 0.2, 0.3\text{nH}$	13 / 500MHz	6	0.45	380
3.1	$\pm 0.1, 0.2, 0.3\text{nH}$	13 / 500MHz	6	0.45	380
3.2	$\pm 0.1, 0.2, 0.3\text{nH}$	13 / 500MHz	6	0.45	380
3.3	$\pm 0.1, 0.2, 0.3\text{nH}$	13 / 500MHz	6	0.45	380
3.4	$\pm 0.1, 0.2, 0.3\text{nH}$	13 / 500MHz	6	0.55	380
3.5	$\pm 0.1, 0.2, 0.3\text{nH}$	13 / 500MHz	6	0.55	380
3.6	$\pm 0.1, 0.2, 0.3\text{nH}$	13 / 500MHz	6	0.55	380
3.7	$\pm 0.1, 0.2, 0.3\text{nH}$	13 / 500MHz	6	0.55	340
3.8	$\pm 0.1, 0.2, 0.3\text{nH}$	13 / 500MHz	6	0.55	340
3.9	$\pm 0.1, 0.2, 0.3\text{nH}$	13 / 500MHz	6	0.55	340
4.3	$\pm 0.1, 0.2, 0.3\text{nH}$	13 / 500MHz	6	0.65	320
4.7	$\pm 0.1, 0.2, 0.3\text{nH}$	13 / 500MHz	6	0.65	320
5.4	$\pm 0.1, 0.2, 0.3\text{nH}$	13 / 500MHz	6	0.85	280
5.6	$\pm 0.1, 0.2, 0.3\text{nH}$	13 / 500MHz	6	0.85	280
5.9	$\pm 0.1, 0.2, 0.3\text{nH}$	13 / 500MHz	6	0.85	280
6.5	$\pm 0.1, 0.2, 0.3\text{nH}$	13 / 500MHz	6	1.05	260
6.8	$\pm 0.1, 0.2, 0.3\text{nH}$	13 / 500MHz	6	1.05	260
7.2	$\pm 0.1, 0.2, 0.3\text{nH}$	13 / 500MHz	6	1.05	260
8.0	$\pm 0.1, 0.2, 0.3\text{nH}$	13 / 500MHz	5.5	1.25	220
8.1	$\pm 0.1, 0.2, 0.3\text{nH}$	13 / 500MHz	5.5	1.25	220
8.2	$\pm 0.1, 0.2, 0.3\text{nH}$	13 / 500MHz	5.5	1.25	220
9.1	$\pm 0.1, 0.2, 0.3\text{nH}$	13 / 500MHz	5.5	1.25	220
10.0	$\pm 1, 2, 3, 5\%$	13 / 500MHz	4.5	1.35	200
10.8	$\pm 1, 2, 3, 5\%$	13 / 500MHz	4.5	1.35	200
12.0	$\pm 1, 2, 3, 5\%$	13 / 500MHz	3.7	1.55	180
13.8	$\pm 1, 2, 3, 5\%$	13 / 500MHz	3.7	1.75	180
15.0	$\pm 1, 2, 3, 5\%$	13 / 500MHz	3.3	1.75	130
17.0	$\pm 1, 2, 3, 5\%$	13 / 500MHz	3.1	1.95	100
18.0	$\pm 1, 2, 3, 5\%$	13 / 500MHz	3.1	2.15	100
20.8	$\pm 1, 2, 3, 5\%$	13 / 500MHz	2.8	2.55	90
22.0	$\pm 1, 2, 3, 5\%$	13 / 500MHz	2.8	2.65	90
27.0	$\pm 1, 2, 3, 5\%$	13 / 500MHz	2.5	3.25	75
33.0	$\pm 5\%$	13 / 500MHz	2.5	4.50	75

AL03 Chip Inductors / Standard Type

Inductance (nH)	Inductance Tolerance (nH or %)	Quality Factor min.	SRF (GHz) min.	DCR (Ω) max.	IDC (mA) max.
1.0	$\pm 0.1, 0.2, 0.3nH$	15 / 300MHz	13	0.35	800
1.2	$\pm 0.1, 0.2, 0.3nH$	15 / 300MHz	13	0.35	800
1.5	$\pm 0.1, 0.2, 0.3nH$	15 / 300MHz	10	0.35	800
1.8	$\pm 0.1, 0.2, 0.3nH$	15 / 300MHz	10	0.35	300
2.2	$\pm 0.1, 0.2, 0.3nH$	15 / 300MHz	8	0.35	300
2.7	$\pm 0.1, 0.2, 0.3nH$	15 / 300MHz	6	0.45	300
3.3	$\pm 0.1, 0.2, 0.3nH$	15 / 300MHz	6	0.45	300
3.9	$\pm 0.1, 0.2, 0.3nH$	15 / 300MHz	6	0.45	300
4.7	$\pm 0.1, 0.2, 0.3nH$	15 / 300MHz	5	0.55	300
5.6	$\pm 0.1, 0.2, 0.3nH$	15 / 300MHz	5	0.65	300
6.8	$\pm 0.1, 0.2, 0.3nH$	15 / 300MHz	5	0.75	300
8.2	$\pm 0.1, 0.2, 0.3nH$	15 / 300MHz	4	0.95	300
10	$\pm 1, 2, 3, 5\%$	15 / 300MHz	4	0.95	300
12	$\pm 1, 2, 3, 5\%$	15 / 300MHz	3	1.05	300
15	$\pm 1, 2, 3, 5\%$	15 / 300MHz	3	1.35	300
18	$\pm 1, 2, 3, 5\%$	15 / 300MHz	2	1.65	300
22	$\pm 1, 2, 3, 5\%$	15 / 300MHz	2	1.95	250
27	$\pm 1, 2, 3, 5\%$	15 / 300MHz	2	2.35	250
33	$\pm 1, 2, 3, 5\%$	15 / 300MHz	1.5	2.75	250
39	$\pm 1, 2, 3, 5\%$	15 / 300MHz	1.5	3.00	200
47	$\pm 1, 2, 3, 5\%$	15 / 300MHz	1.5	3.00	200
56	$\pm 1, 2, 3, 5\%$	15 / 300MHz	1	5.00	150
68	$\pm 1, 2, 3, 5\%$	15 / 300MHz	1	5.00	150
100	$\pm 2, 3, 5\%$	15 / 300MHz	1	7.50	100

Environmental Characteristics

Item	Requirement	Test Method
Inductance	As Spec.	Measuring equipment and fixture: 0201: HP4287+Agilent 16196C 0402: HP4287+Agilent 161 96B 0603: HP4287+Agilent 161 96A
Insulation Resistance	>1000M Ω	Apply 100V _{DC} for 1minute
Damp Heat with Load	$\Delta L \leq 10\%$	40.2C, 90~95% R.H. Max. working voltage for 1000 hrs with 1.5 hrs "ON" and 0.5 hrs "OFF"
Bending Strength	As Spec.	Bending Amplitude 3mm for 10 seconds
Solderability	95% min. coverage	245 \pm 5 $^{\circ}$ C for 3 seconds
Resistance to Soldering Heat	$\Delta L \leq 10\%$	260 \pm 5 $^{\circ}$ C for 10 seconds
Dielectric Withstand Voltage	>100V	Apply 100VA (rms) for 1minute
High Temperature Exposure	$\Delta L \leq 10\%$	85 \pm 2 $^{\circ}$ C, 1000 +48/-0 hours
Low Temperature Storage	$\Delta L \leq 10\%$	-40 \pm 3 $^{\circ}$ C, 1000 +48/-0 hours
Temperature Cycle	$\Delta L \leq 10\%$	-40/RT/85/RT, 10 cycles

- Reference Standards: MIL-STD-202F, JIS-C 5201-1
- Storage Temperature: 25 \pm 3 $^{\circ}$ C; Humidity < 80%RH

Packaging

Reel Specifications & Packaging Quantity

Unit: mm

Type	ΦA	ΦB	ΦC	W	T	Quantity (EA)
AL01	178.0 ± 1.0	$60 + 1.0$	13.5 ± 0.7	9.5 ± 1.0	11.5 ± 1.0	10,000
AL02	178.0 ± 1.0	$60 + 1.0$	13.5 ± 0.7	9.5 ± 1.0	11.5 ± 1.0	10,000
AL03	178.0 ± 1.0	$60 + 1.0$	13.5 ± 0.7	9.5 ± 1.0	11.5 ± 1.0	5,000

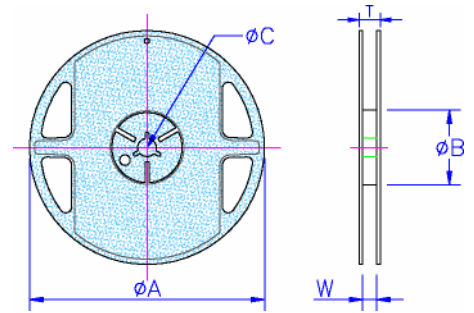

Paper Tape Specifications

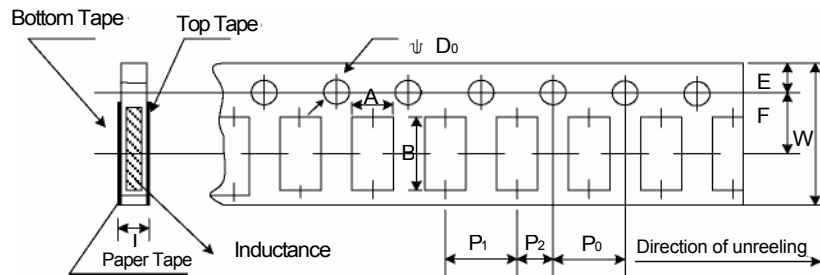

Unit: mm

Type	A	B	W	E	F	P ₀	P ₁	P ₂	ΦD_0	T
AL01	0.40 ± 0.05	0.70 ± 0.05	8.00 ± 0.10	1.75 ± 0.05	3.5 ± 0.05	4.00 ± 0.10	2.00 ± 0.05	2.00 ± 0.05	1.55 ± 0.03	0.42 ± 0.02
AL02	0.70 ± 0.05	1.16 ± 0.05	8.00 ± 0.10	1.75 ± 0.05	3.5 ± 0.05	4.00 ± 0.10	2.00 ± 0.05	2.00 ± 0.05	1.55 ± 0.05	0.40 ± 0.03
AL03	1.10 ± 0.05	1.90 ± 0.05	8.00 ± 0.10	1.75 ± 0.05	3.5 ± 0.05	4.00 ± 0.10	4.00 ± 0.10	2.00 ± 0.05	1.55 ± 0.05	0.60 ± 0.03